



## **Product Catalogue** 2025/2026



## References



## Scan and Browse!



[www.teconcept.de](http://www.teconcept.de)



## Content of this booklet:

References .....	2
Scan and Browse! .....	2
Welcome to TEConcept GmbH .....	4
IO-Link Introduction .....	6
IO-Link Pathfinder .....	7
IO-Link Workshops .....	8
IO-Link Safety .....	9
IO-Link Safety Master Stack .....	10
Safety Master Tester .....	11
IO-Link Tools and Utilities .....	12
Diagnosis Tool .....	13
IO-Link Spy .....	14
Configurable-Observable Device .....	15
IO-Link Devices .....	16
IO-Link Device Stack V1.1.4 .....	17
Device Stack Extension Parameter Handler .....	18
Device Stack Extension Bootloader .....	19
Device Stack Extension BLOB Transfer .....	20
IODD Studio .....	21
Device Tester V1.1.4 .....	22
Physical Layer Tester .....	23
EMC Test Master .....	24
IO-Link Master .....	25
IO-Link Master Stack V1.1.4 .....	26
Master Stack Extension SMI-based Master Bootloader .....	27
Master Stack Extension Serial Transport Layer (TSTL) .....	28
Master Stack Extension SMIT Serial Transport Layer Library .....	29
Master Stack Extension SMI Test Communication Server .....	30
JSON Integration for IO-Link .....	31
IODD Parser in C .....	32
SMI Communication Client .....	33
SMI Composer Parser in C# .....	34
1-Port USB-C Master .....	35
4-Port USB Master .....	36
1-Port Master Module .....	37
4 Port Master Module .....	38
4-Port Ethernet IO-Link Master .....	39
Master Tester V1.1.4 .....	40
EMC Test Device .....	41
Distributors .....	42
Partnerships .....	43
IO-Link-Competence Center .....	44
IO-Link-Test Center .....	45
Declaration of Tool Acceptance .....	46
References .....	47
Scan and Browse! .....	47
Contact .....	48



## Welcome to TEConcept GmbH, Where Expertise Meets Innovation

### Who are we?

For over two decades, TEConcept has been supporting companies through all phases of the product life cycle - from the initial idea to the certified electronic assembly. Although technical requirements are constantly increasing, we deliver precise solutions for IO-Link, engineering tools, and hardware development.

### Why choose TEConcept?

#### Innovative strength & industry expertise

For many years, TEConcept has been working closely with leading companies in automation technology - particularly in the field of IO-Link sensors and IO-Link masters. Thanks to this in-depth market knowledge, we develop products that are both technically advanced and economically viable.

#### Development partnership on equal terms

Whether you are planning a new IO-Link sensor application or want to expand your existing PLC programming, TEConcept will support you on equal terms. We do not see ourselves as a mere supplier, but as a technical development partner who provides reliable support even for complex projects

#### Secure integration & long-term support

That's why our service doesn't end with the purchase - rather, that's where our partnership-based support begins.

### IO-Link Development (See next page!)

Most of the time, the following steps have to be taken to develop a successful IO-Link product:

#### Concept & Validation

- Shared understanding of system goal & feasibility
- Rough architecture and interface planning
- Initial assessment of feasibility & profitability

#### Architecture & Technology Selection

- Selection of MCU, IO-Link Stack, peripherals & tools
- Recommendations for integration into existing platforms
- Decision support: Buy vs. Build

#### Development & Integration

- Firmware & hardware development
- Stack adaptation, IODD, error handling and close support from experienced IO-Link experts

#### Test, Certification & Market Launch

- Prepare IO-Link certification - before problems arise
- Testing with emulator & diagnostic tools before market launch
- Smooth launch through debug support during commissioning





## Bringing system and clarity to a certified, market-ready product.

In 4 steps to scalable product success!

Thanks to the **generic TEC IO-Link design**, you can access **global markets** and bring not just **prototypes**, but also **best-selling products to market**.

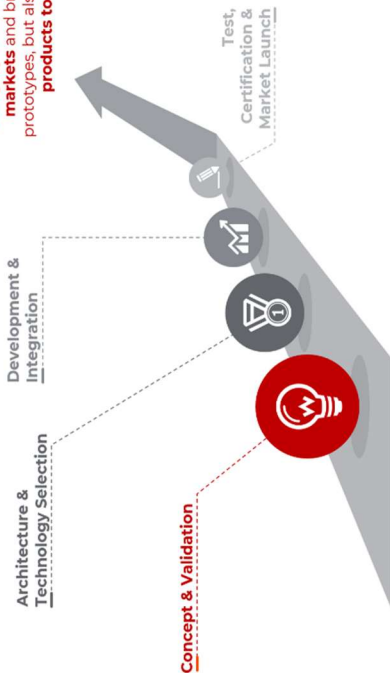



### What is IO-Link?

According to the IO-Link Community (<https://io-link.com/>), IO-Link is the first globally standardized IO technology (IEC 61131-9) for **communicating with sensors and actuators**.

The transfer rate for the IO-Link operation mode are set to:

- COM 1: 4.8 kBaud, 18ms cycle time\*
- COM 2: 38.4 kBaud, 2.3ms cycle time\*
- COM 3: 230.4 kBaud 0.4 ms cycle time\*

\* For 2 bytes process data and 1 byte service data

Data can be transferred either as cyclic data, which is true for process data up to 32 bytes, or acyclic, which applies for parameter, configuration, setting data, device identification and events such as warnings, errors and notifications. There are no material requirements for the 3, 4 or 5-wire point-to-point standard cables. IO-Link is **fieldbus-independent** and for every IO-Link Device is described with an IO Device Description (**IODD**). The communication between an IO-Link Master and an IO-Link Device includes measured values and setpoints, device parameters, diagnostic and error messages.

### IO-Link Community

The IO-Link Community is a global consortium and brings manufacturers, developers and users together to ensure **interoperability** and innovation in industrial automation. Everybody is welcome to further develop the standard in the IO-Link working groups, which work on the **Specifications**.

### IO-Link Specifications

To distribute an IO-Link product you must comply with the IO-Link Community rules. They are available in the Download Section of the IO-Link webpage. Very important are the IO-Link **Interface and System Specification**, the **IO Device Description Specification** and the **IO-Link Test Specification**. Also, the Community is working on further standardization such as the published IO-Link BLOB Transfer and Firmware Update Profile.

### IO-Link Extensions

IO-Link provides the **IO-Link Wireless** for harsh environments, such as sensors and actuators on moving and rotating machine parts. Another Extension is **IO-Link Safety**, which is discussed in a later segment (see page 9).

### IO-Link in Smart Industry

IIoT can be used directly to connect the IO-Link Master with IIoT interface to the IT world. For example temperature and vibration data from an IO-Link sensor can be sent directly to the cloud and can be analyzed for with an AI-based system to detect anomalies for predictive maintenance, for example.

### IO-Link Product Quality Policy

IO-Link Products must meet a high standard to ensure error-free operation and manufacturers must declare this in the **manufacturer declaration (MD)**. Therefore IO-Link Devices and IO-Link Masters must pass the **protocol test**, the **physical layer test** and the **EMC test**. IO-Link Devices are also checked for a valid IODD. Non IO-Link Community members must hire an **IO-Link Test Centre** (e.g. TEConcept) to test their IO-Link Product and to receive the "Confirmation of completion of conformance tests". They also must follow the **IO-Link License Model**. IO-Link members are permitted to perform the tests on their own: For easier and faster testing regarding the Test Specification the use **test tools accepted by the IO-Link Community** (such as TEConcept's IO-Link Test Tools) can be helpful.

### Advantages

- Signal is not influenced by EMC and can even lay close to FC motor cables
- Digital signal: No calibration of the distance sensor - controller
- Logging and storage of parameters with MES system
- Change of parameters can be locked without the loss of read rights
- IIoT/IIoT applications possible



Use

 **IO-Link**  
Universal · Smart · Easy

## IO-Link Pathfinder



### Your current situation is as follows

- Do you have an initial idea for a product with new features in topics such as maintenance or IoT?
- Is your task to implement IO-Link in an existing product due to market adaptation or customer requirements?
- Have you heard of IO-Link but are unsure whether integration is worthwhile for your product?
- Would you like to convince your management of the benefits of IO-Link but are still looking for arguments?

### Overview

The IO-Link Pathfinder is aimed at technical project management, product management, and development and is offered as a split workshop with two 2-hour sessions. The first half focuses on the target vision and use case (1) and the analysis of the current system architecture (2). In the second half, a critical assessment of technological maturity and IO-Link fitness (3) is carried out, and a recommended action and priority plan (4) is discussed and defined. The aim of the IO-Link Pathfinder is to work with you to develop a roadmap for implementing your planned project that is tailored to your IO-Link requirements. However, the entire process is designed to be completely open in terms of results and technology. One possible outcome may therefore be that IO-Link is not the best solution for your product requirements.

### Deliverables

- System architecture analysis by experienced IO-Link developers
- Roadmap for IO-Link introduction
- Recommended course of action
- Satisfaction guarantee: If you are not satisfied with the results of the workshop, you will receive a refund.



### Overview

As an official IO-Link Competence & Test Center, TEConcept offers training courses and workshops worldwide to help you start, expand, and deepen your company's expertise in IO-Link. Our IO-Link experts have more than 15 years of experience in IO-Link development services.

### IO-Link Basics

Ideal for beginners who want to gain a comprehensive overview of IO-Link systems, communication mechanisms, and system elements:

- General overview and system introduction
- IO-Link system elements and communication mechanisms
- Master/fieldbus mapping and integration
- IO-Link profiles and system extensions
- IO-Link Safety extension – understanding and implementing secure communication
- IO-Link Smart Sensor profile – intelligent sensor technology in practice
- Firmware and BLOB profile – data management and firmware updates

### IO-Link architecture and development

This workshop offers in-depth insights into the IO-Link system architecture and its practical implementation.

- Detailed IO-Link system architecture with practical insights
- Communication models and parameters – understandable and application-oriented
- Integration into automation systems with a focus on efficient implementation

- Advanced development of device applications and master gateway implementations

### IO-Link conformity tests and tools

This workshop focuses on topics such as IODD design, use of our tools (e.g. IODD-Studio, Device Tester, COD, Diagnosis Tool) and other technical details

- IO-Link conformity tests: physical layer, protocol and EMC testing
- Special tools for development and testing – efficient and reliable
- IODD design and maintenance with IODD Studio
- Tips and tricks for efficient testing, debugging, and automated processes

### Deliverables

- The training courses are available in two formats: on-site worldwide or online
- The duration and agenda of the training courses are tailored to your individual needs. However, we recommend a maximum of 4 hours per day
- The workshops are available in English, German and Hungarian



Use  **IO-Link**  
Universal · Smart · Easy

## IO-Link Safety

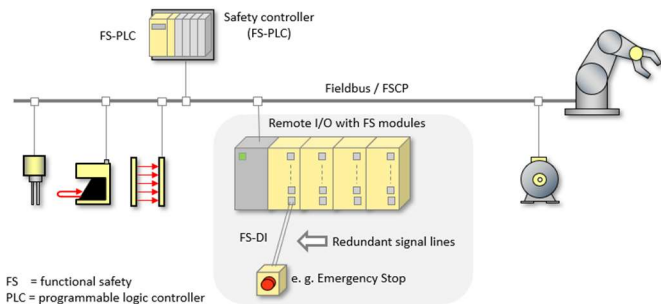

### What is IO-Link Safety?

The **IO-Link Safety System Extension** offers all the advantages known from the "Standard" IO-Link including the black channel to transmit the data point to point, therefore the communication protocol is much more simpler than, for example, safety protocols for fieldbus systems. From an architecture point of view the IO-Link Safety Master can not only be used for connecting OSSD sensors but also to use SIO Devices at the same time. This mixed application makes the use of functional safety and standard functionality easier and reduces costs. Besides the FS-Safety Masters, IO-Link Safety is feasible for sensors and actuators then called FS-Safety Devices.

## IO-Link Safety Master Stack

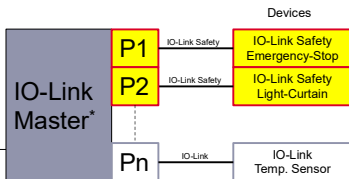
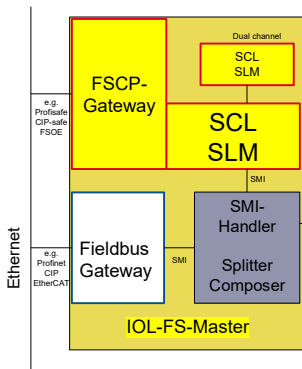

\* With safety extension (ready pulse support, etc.)  
FSCP – functional safety communication profile  
SCL – Safety communication Layer  
SLM – Safety Layer Manager  
SMI – Standard Master Interface

### Overview

The TEConcept IO-Link Safety master stack provides a simple way to extend a regular IO-Link Master to an IO-Link Safety Master. The regular IO-Link Master as part of the IO-Link black channel only needs minor modifications to support, for example, ready pulses, but it does not contain safety related elements.

### Functional Description

The FSCP (Functional Safety Communication Profile) Gateway exchanges safety related process data with the IO-Link Safety Communication Layer (SCL) and the related Safety Layer Manager (SLM). For SIL3 support it is highly recommended to implement SLM and SCL with two channels redundantly.

A Fieldbus-Gateway is added to exchange non-safe process data as well as configuration, status information.

SMI handler and Splitter Composer are extensions of the IO-Link black channel and responsible for routing SMI services handling of safe and non-safe process data.

The TEConcept solution of the IO-Link Safety Master Stack supports multiple architectures. It supports the reuse of an existing IO-Link Master with SMI support, but also architectures where the IO-Link Master and the fieldbus gateways share the same MCU.

### IO-Link FS Master Stack features

- SMI communication between blocks
- Module certification from named body in preparation
- Support of IO-Link / IO-Link FS V1.1.5

### Advantages

- Reuse of existing IO-Link Master Architectures with SMI interface supported
- Clear separation between safe and non-safe parts
- Hardware independent implementation
- Simplified Assessment of the IO-Link FS Master due to use of pre-certified software module

### Restrictions

- OSSDe requires legacy FS-DI or FS-DO support

### Deliverables

- Pre-certified IO-Link Safety Master Stack
- Quality manual
- Master Tool Windows Application (for development purposes) with Device Tool Interface
- Development support (optional)



Use **IO-Link**  
Universal · Smart · Easy

## Safety Master Tester

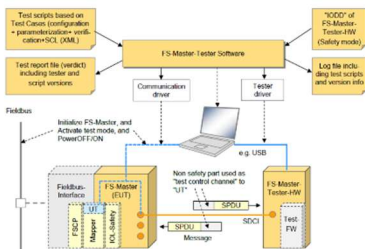

### Overview

Every manufacturer of IO-Link Safety Masters needs to run tests specified in the current IO-Link Safety Test specification V1.1.3 successfully as precondition for the assessment of a named body (e.g., TÜV). Precondition for Safety tests are the Standard IO-Link Master Tests that are executed by a different tool.

IO-Link Test Specification describes tests of the Safety Communication Layer "SCL" based on test vectors that were automatically generated and approved by a named body (IFAK tests).

To run the Safety Tests, the Master Manufacturer must implement an Upper Tester (UT) and an SMI Test Communication Server.

The IFAK test vectors are submitted by the Safety Master Tester Unit to the Master Under Test. Some additional test cases, such as the Splitter / Composer test are triggered via the STCS.

### Advantages

- Highly automated test of IO-Link Masters
- Automatic report generation
- Support of Safety assessment of named bodies
- One year maintenance included

### Safety Master Tester Features

- Test system for automated, reproducible Safety Master tests according to the latest IO-Link Safety Test specification
- PDF Report Generation
- Simultaneous test of multiple ports supported (requires additional MTUs)
- SDK for SMI Test Communication Server
- Maintenance extension provided
- Option for additional SMTUs

### Deliverables

- Safety Master Tester app "SMTA" installer
- VID locked license key (for Master manufacturers)
- Optional unlocked license key for Test labs
- One Safety Master Tester Unit "SMTU"
- USB-Cable
- SDK for SMI Test Communication Server
- Python based SMI control-application

### Availability

- In stock



### What are IO-Link Tools and Utilities?

The development of IO-Link devices and masters requires a deep understanding of communication mechanisms and precise coordination between hardware and software. To make this process efficient, developers now have access to a wide range of specialized tools and utilities that support all phases of the development cycle—from the concept phase to implementation, testing, and certification.

### IO-Link Tools

Development tools facilitate entry into IO-Link technology by providing functions for protocol analysis, parameterization, and communication testing. They enable early verification of implementations and make communication behavior traceable.

### Utilities

Utilities such as emulation or configuration tools complement this process by creating virtual device environments or specifically simulating IO-Link systems. This allows developers to test functions before real hardware is available or reproduce complex scenarios to ensure the robustness and interoperability of their products.

### Advantages

The targeted use of these tools can shorten development times, reduce risks, and significantly increase the quality of the final IO-Link products. They thus form the backbone of a professional development process—both for device and master manufacturers.

Further advantages include:

- Early validation through testing with emulation tools enables software errors to be eliminated at an early stage, even without finished hardware
- Emulation tools reduce the need for expensive prototypes
- Tools are often directly compatible with the IO-Link stack or the test framework used
- Diagnostic tools can be used to track internal communication states, process data, and event messages in order to identify errors
- Test tools allow tests to be automated and repeated in a reproducible manner in order to test the device under investigation for communication errors and timing problems and to eliminate errors before certification
- Standardized tools reduce the training time required for new developers and technicians and make it easier for them to work with IO-Link

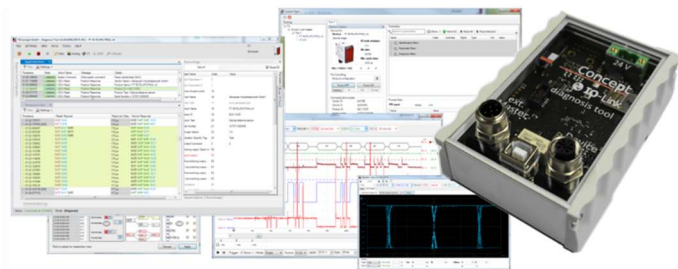

### Overview

The IO-Link Diagnosis Tool analyzes the IO-Link signal both electrically and logically. It is an essential tool for engineers and users of IO-Link technology to identify any kind of issues in the IO-Link connection.

### Functional Description

The Diagnosis Tool is based on a high-speed multi-channel A/D converter that measures voltages and currents on both the C/Q and the L+ line. The measured data are transferred via USB to a software application running on a Windows PC.

The IO-Link communication can be analyzed seamlessly at byte-level, at M-sequence level, at protocol level and even at application level. In the latter case, the IO-Link communication is visible in clear text. Folding, filtering and search functions simplify issue identification.

It is also possible to visualize sections as waveforms, and even eye-diagrams for Master and Device signals can be extracted.

Typically, the Diagnosis Tool is inserted between Master and Device. However, an **integrated Master** allows checking of Devices without an external Master. The tracked communication is shown and recorded directly on a PC.

### Diagnosis Tool Features

- Timing accurate IO-Link signal analysis
- High speed, IO-Link synchronized ADC
- Timing precise software UART decoding
- Optional hardware signal direction detection
- Byte-, frame-, protocol- or IO-Link-based decoding
- Sophisticated filtering and search features
- Device image collection of all data sent
- Data storage image collection

- Recording of IO-Link byte stream to PC/SD-card
- Analog signal view for UL+, IL+, UCQ, ICQ
- Serial decoding in analogue waveform view
- Eye diagram view separated for Device/Master
- Interactive rulers for analogue measurements
- Trigger-Out connector
- User calibration support
- Integrated Master

### Advantages

- Fast and easy IO-Link issue analysis
- Logical and electrical issue detection
- Suitable for development and application

### Deliverables

- IO-Link Diagnosis Tool
- 24V power supply, USB cable
- Windows-based graphical user interface

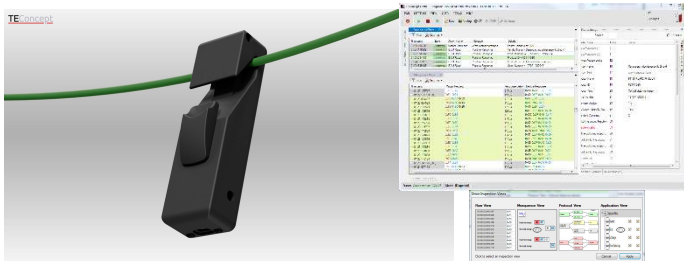

### Overview

The IO-Link Spy enables logging and analysis of IO-Link communication. To do this, the IO-Link Spy is simply clipped to the IO-Link cable. It is an essential tool for engineers and users of IO-Link technology to identify any kind of issues in the IO-Link communication without affecting the operation/communication in any way.

### Functional Description

The IO-Link signal is tapped via capacitive coupling. Through amplification, filtering, and digital signal processing, the original signal is finally recovered. The measured data are transferred via USB to a software application running on a Windows PC.

The IO-Link communication can be analyzed seamlessly at byte-level, at M-sequence level, at protocol level and even at application level. In the latter case, the IO-Link communication is visible in clear text. Folding, filtering and search functions simplify issue identification.

As the IO-Link Spy is simply attached to an IO-Link cable, there is no need to interrupt an ongoing IO-Link communication. This is particularly useful for analyzing problems during operation or for errors that occur only very sporadically.

If needed, an additional ground connector can be used to improve the signal quality, though in most cases it functions perfectly well without one.

### IO-Link Spy Features

- Timing accurate IO-Link signal analysis
- Timing precise UART decoding
- Byte-, frame-, protocol- or IO-Link-based decoding
- Sophisticated filtering and search features
- Device image collection of all data sent
- Data storage image collection

### Advantages

- Logging IO-Link communication without interrupting the ongoing communication
- Fast and easy IO-Link issue analysis
- Detection of logical issues
- Suitable for development and application

### Restrictions

- There must be no other (digital) signals on the line (other than IO-Link communication)
- Too much electromagnetic disturbance in the environment might cause issues in recovering the original IO-Link signal

### Deliverables

- IO-Link Spy
- Ground connector cable
- USB cable
- Windows-based graphical user interface

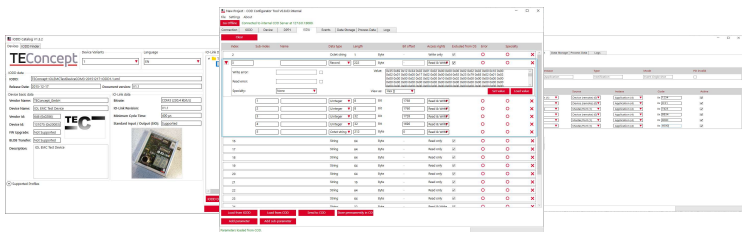

### Overview

The Configurable-Observable Device (COD) is a special IO-Link Device that emulates the IO-Link behavior of other IO-Link Devices. Additionally, the COD can be configured to simulate typical issues of IO-Link Devices, like improper timing, unexpected events, response errors, etc. Some examples of use cases where emulation of IO-Link Devices are needed are:

- Testing of IO-Link Masters
- Testing of IO-Link Parameterization Tools
- Designing the User Interface of an IO-Link Device
- Regression Testing

### Description

The COD is an IO-Link Device that can be configured and parameterized via REST API. The actual hardware communicates with the PC via USB. The REST API is provided by a PC-side server application called COD Communication Server.

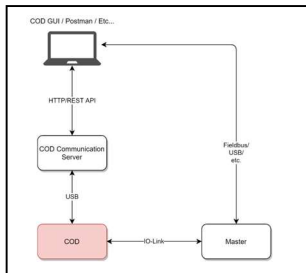

### Features

- REST API for configuration and observation in automated test systems
- PC application for easy configuration
- Emulates IO-Link Device by using its IODD
- Fully configurable dynamic ISDU parameter handling, with settable error generation for each index and sub-index
- Configurable DPP1 values (e.g. cycle time, process data, vendor and device ID, etc.)
- Event generation
- Process data mirroring, generation
- Observation of IO-Link communication and internal device variables (e.g., startup sequence, data storage flags)
- Error generation (e.g., emulation of a faulty device)
- Non-volatile memory to store configured parameters permanently

### Advantages

- Easy integration in CI/CD pipelines
- Test data generation for testing Host side applications (e.g., IO-Link configurator tools)

### Deliverables

- 1 COD hardware
- PC configurator application
- COD Communication Server application
- REST API description (yaml file)

### What is an IO-Link Device?

The serial communication IO-Link technology allows transmission of parameterization and diagnostics data. This digital communication has advantages such as a reduction in system downtimes by using the DataStorage Configuration and predictive maintenance compared to analog or digitally switching sensors and actuators.

Basic low energy consuming IO-Link devices are connected with an unscreened 3, 4 or 5 wire standard cable M5, M8 or M15 up to a length of 20m to a master. The Pin 1 and Pin 3 are used for the power supply of 24V and the Pin 4 for the switching and communication (C/Q). In Port Class A usually Pin 2 can be used as an additional digital channel. In the Port Class B configuration the Pin 2 and Pin 5 are used for an additional power supply. This could be the case for high energy consuming actuators

### IODD (IO Device Description)

The IODD is an electronic datasheet for IO-Link Devices, structured as shown in the following figure.

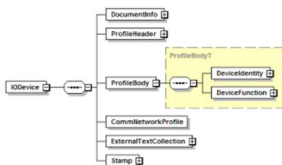

The IODD is provided as a set of files in a Zip and is structured the same for all devices from all manufacturers regarding the specifications. Use the IODDfinder (<https://io-link.com/community/services/ioddfinder>) to get more information about the available IODDs. The IODD contains the following information:

- Communication characteristics
- Device parameters with value range and default value
- Identification, process and diagnostic data
- Device details (Manufacturer ID, Device ID)
- Text description
- Image of the device
- Manufacturer's logo

### Advantages

Thanks to the IODD plug-and-work functionality, adding new devices does not change the overall system architecture. Due to the so called DataStorage mechanism implemented in IO-Link Devices and Masters, the master can save the current device parameters and in case the device fails, a replaced device can be easily reconfigured without any additional software tools. Also, device manufacturers do not have to worry about the communication to upper layers of the automation pyramid. This is part of the IO-Link masters and devices only have to communicate with the IO-Link protocol.

### Smart Device Profiles

Smart sensor profiles are already specified and contain a new switching scheme, a new subprofile, uncertainty indication and the teach window. This showed that the harmonization of frequently used parameters is necessary for more interoperability. Smart device profiles besides sensors are possible for actuators, diagnosis and identification and are seen by the community as another step on the way to more efficient integration of devices.



### Overview

Current sensors and actuators are equipped with small but powerful microprocessors that introduce advanced features such as parameterization and diagnostics to these devices. **IO-Link™**, is a bi-directional, digital, point-to-point communication standard (IEC 61131-9) which offers standardized mapping of advanced sensor and actuator features into the automation tool environment.

Our IO-Link software stack provides sensor and actuator manufacturers a cost efficient and easy way to integrate state-of-the-art IO-Link technology into their products.

### Specifications

- Compliant to V1.1.4 IO-Link communication specification
- Synchronous or asynchronous process data handling
- Data storage
- Process synchronisation
- Footprint: RAM: ~2.5 kB, Flash: ~12 kB
- Porting to different  $\mu$ Cs and IO-Link PHYs requires only an exchange of drivers
- Any combination of following portings is available:



### License Model

- Royalty-free license
- One-year maintenance included
- Full source code

### Deliverables

- Fully ported stack operational on the target hardware platform
- Driver for target processor architecture
- Driver for target IO-Link PHY
- IO-Link demo application
- Compiler and Linker setups for target development environment
- API reference manual

### Additional Services

- IO-Link consulting and additional technical support
- Customized IODD development
- IOL-Device and Master Hardware and Software design
- Options: BLOB, Firmware Update and Parameter Handler available
- Supply of development tools such as
  - USB master (1-port, 4-port)
  - Conformance Test systems
  - IODD-Design tool
  - Reference designs

▪ Microcontroller	▪ PHY
▪ ATmega	▪ CCE4501/2
▪ ATSAMd	▪ HMT7742/8
▪ dsPIC33	▪ iC-GF
▪ GD32Fx	▪ L6362A, L6364
▪ HC32Fx	▪ LT3669-2
▪ MAX32660	▪ MAX1482x
▪ MSP430, MSPM0	▪ MAX22513/5
▪ NXP LPXxx, S32xx, i.MX	▪ MAX22516/22
▪ PSoC	▪ RH4Z2501
▪ RL78/xxx	▪ SN65HVD101
▪ STM32xxx	▪ TIOL112
▪ STM8L/STM8S	▪ ... and many more

## Device Stack Extension Parameter Handler

### Overview

The Parameter Handler is an add-on to the TEConcept IO-Link Device Stack which lets the user easily implement lots of ISDU parameters. The parameter handler takes care of DataStorage and block parameterisation. It additionally provides an interface for non-volatile storage of parameters. The user can stay focused on implementing the technology application, using a simple interface to define and access ISDU parameters. The Parameter Handler takes care of the required two parameter sets, provides call-back functions for cross-checks, and implements the parameter reset functions.

### Functional Description

All ISDU parameters are defined in table format. For each parameter name, index/subindex, datatype, array length, access rights etc. are defined. Parameters can be accessed from the application by simple getter/setter functions using parameter names. Additionally, for each parameter, different call-backs can be defined which are called on read or write access by the IO-Link Master or for parameter consistency check.

Most read-write parameters must be stored in non-volatile memory. A module is provided with the Parameter Handler which handles non-volatile storage including a checksum to prevent data corruption. The user only needs to implement the actual storage in EEPROM.

The Parameter Handler uses the API of the Device Stack and implements the required call-back functions. Time-consuming tasks of the Parameter Handler are processed from a separate function which must be called cyclically from main loop or as OS task.

### Intended Use

Applications which already have structures to handle parameters should use the Device Stack API directly and do not need the Parameter Handler. The Parameter Handler is intended for applications which do not yet have a handling mechanism for parameters and non-volatile memory.

### Advantages

The Parameter Handler considerably simplifies implementation of arrays or records. Access to subindices or to the whole parameter is provided (restriction: subindices must be aligned to byte boundaries). Blocktransfer and DataStorage are handled automatically including creating the IndexList. SystemCommands, DeviceReset, ApplicationReset and Back-to-Box are also covered.



### Deliverables

- Source Code. Standard ISDU Parameters and some Demo parameters are implemented
- Interface for non-volatile storage of ISDUs
- User manual

### License Model

- Royalty-free license
- Full source code
- The Parameter Handler is only sold together with the IO-Link Device Stack



### Overview

In 2016 the IO-Link community published the BLOB Transfer and Firmware Update profile the first time. This profile supports firmware updates via the IO-Link interface. It is fully compliant to the IO-Link V1.1.x specification. Thus, every standard IO-Link Master can be used to update the firmware of an IO-Link device, if the master is controlled by an appropriate software tool that can read and process the specified firmware update files. The firmware update files can be generated by a tool which is part of the delivery package.

The bootloader transfers a binary image to the device. It receives and checks the image date. Post-processing (de-compression, decryption etc.) and the storage of the image data is device specific. The bootloader provides an appropriate extension interface.

### Functional Description

The bootloader contains a minimized IO-Link Device stack and runs as a standalone firmware on the IO-Link device. It updates the so-called technology firmware (TFW) which contains the complete Device Stack and the Device application.

### Features

- Complies to Firmware-Update profile V1.2 (Sept. 2024)
- Can be added to an existing IO-Link Device
- Tolerant to power failures and transmission errors during the update process
- Footprint: RAM: ~2.5 kB / Flash: ~12 kB
- Supported development platforms: Keil, Eclipse/GCC, IAR

### Deliverables

- Buyout license for Firmware Update Bootloader
- Documentation with installation manual
- Compiler & linker example setups
- Firmware update package creator tool

### Additional Services

- Demo Device with bootloader
- Software/Hardware design support
- Conformance tests

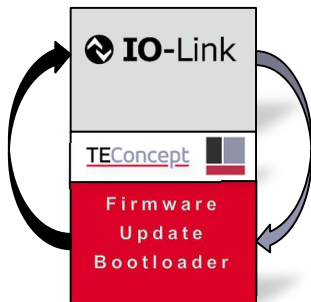

### Overview

In 2016 the IO-Link community published a profile that supports BLOB transfer and firmware updates via the IO-Link interface. BLOB stands for Binary Large Object. While ISDU transfers are limited to 232 bytes per parameter, the size of BLOBs is limited to 4 giga byte. The size is therefore limited by accepted transmission time rather than the actual size.

BLOB can be used to transfer huge data sets from or to an IO-Link device, e.g. log files, FFT data, calibration data, etc.

This profile is fully compliant to the IO-Link V1.1.x specification. BLOB transfer uses ISDUs as transport vehicle. Thus, every standard IO-Link Master can be used for BLOB transfer, if the master is controlled by an appropriate software tool that implements the BLOB host.

### Implementation

BLOB transfer is implemented as a Device Stack module which can be added to the TEConcept Device Stack.

### Functional Description

BLOB transfer uses ISDUs as transport vehicle. Thus, every standard IO-Link Master can be used for BLOB transfer, if the master is controlled by an appropriate software tool that implements the BLOB host.

### Features

- Complies to IO-Link Profile "BLOB Transfer & Firmware Update", Version 1.2, September 2024
- Footprint: RAM: ~0.12 kB / Flash: ~3 kB
- Independent of hardware platform and development platform

### Deliverables

- Source Code including sample application and test BLOB IDs for the protocol test
- User manual

### License Model

- Royalty-free license / Full source code
- The BLOB module is only sold together with the IO-Link Device Stack

### Additional Services

- Software design support
- Conformance tests





Use

**IO-Link**  
Universal · Smart · Easy

## IODD Studio

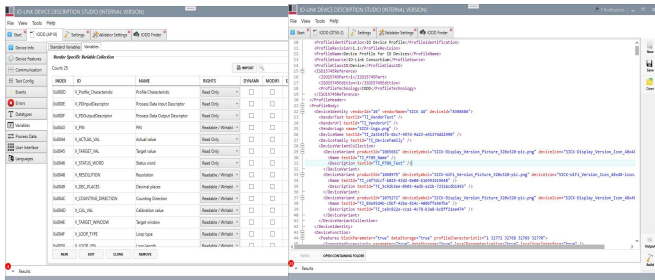

### Overview

IO-Link devices need to be described by IO-Link Device Descriptions called "IODD". These IODD are complex structured XML files with numerous restrictions and interdependencies. Editing an IODD can become a laborious and tedious task and it is difficult to maintain integrity between device and IODD in case of modifications.

TEConcept has developed the IODD Studio application that simplifies the editing of IODDs significantly.

The IODD Studio is a flexible tool which lets the user create the desired IODD and only gives feedback about errors found by the custom validators. For this reason, this tool is recommended for users with experience working with IODD files. The IODD Studio supports creation of new IODDs from scratch as well as import and modification of existing IODDs. The user can also customize the validation rules that are enforced on the created IODD.

Created / modified IODDs can be checked and "stamped" by using the official IODD checker from the IO-Link webpage.

### Deliverables

- Installer for PC-Software

### IODD Studio Features

- Complies to IO-Link Interface Specification V1.1.4
- Wireless IODD Support
- Configurable IODD Validators
- Current project status can be saved and re-stored
- Integrated IODD Finder
- IOLFW Package Creator
- Integrated XML Viewer / Editor
- BLOB Transfer Profile Support
- Firmware Download Profile Support
- Identification & Diagnosis Profile Support
- Import elements from existing IODDs
- Installer for Windows 7/8/10/11

### Advantages

- Speed up of IODD editing
- XML know-how not required
- Import and modification of IODDs supported
- Flexibility
- Configurable input validation
- Vendor specific IODD Template creation

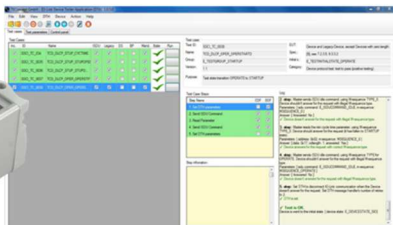

### Overview

Every manufacturer of an IO-Link compliant Device needs to issue a manufacturer's declaration of compliance.

This requires that numerous tests that are defined in the IO-Link test specification must be executed. This Device Tester simplifies the execution of many of these protocol compliance tests. The TEConcept Device Tester is powered by an external 24V power supply, controlled via a USB port and offers a standard M12 connector to connect the Devices Under Test "DUT". A PC software tool imports the IODD of the DUT and automatically adjusts most of its test procedure parameters according to the capabilities of the DUT.

The test cases are defined by XML-files that are accessible by the user.

Additional tests such as checking the validity ranges of device-specific parameters can easily be added by extending the test procedures in XML.

### Deliverables

- Device Tester Hardware
- 24V power supply
- Device Tester Application (Windows based)

### Device Tester Features

- Complies to IO-Link Test specification V1.1.4
- IO-Link profiles (Firmware Update, BLOB Transfer, etc. are supported)
- Extendible with customer specific test cases
- USB control
- External 24V/300mA power supply
- Class A M12 IO-Link master connector
- Approved by IO-Link Quality Working Group

### Device Tester PC Application Features

- Graphical User Interface
- Test Report generation in PDF format
- Selectable Test Case execution
- Step-By-Step test report
- Hex-Trace of IO-Link communication
- Log- and Trace File export
- Session store/restore (project file)
- Firmware update feature
- Temporal downgrade to a USB master is possible

### Command Line Interface is available separately!

An optional command line interface plugin is available that allows the user to start Device Tests from Windows command line. With this feature Device Protocol Tests can be part of CI/CD.

### Additional Services

- FWDL: Test for IO-Profile BLOB Transfer & Firmware Update



## Physical Layer Tester

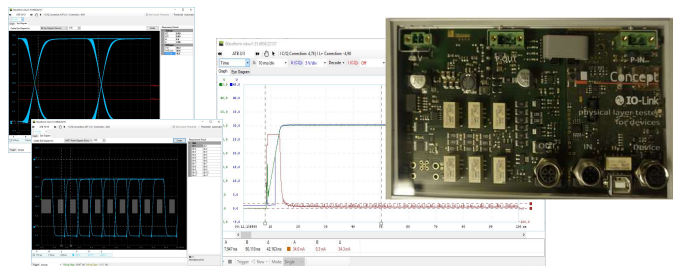

### Overview

TEConcept has developed a Physical Layer Tester "PLT" for Devices to run Physical Layer Tests according to the IO-Link Test Specification. The Physical Layer Tester is powered by an external 48V power supply; it is controlled via a USB port and offers a standard M12 connector for the Devices Under Test "DUT".

A PC software tool asks for the IODD of the DUT and automatically adjusts most of its test procedure parameters according to the capabilities of the DUT. The test cases are defined by XML files that are accessible by the user.

### Functional Description

The PLT is based on a high-speed multi-channel A/D converter that measures voltages and currents on both the C/Q and the L+ line. For every test case, a specific snapshot of signals is taken and stored. In order to generate these signals, the PLT includes all necessary elements, such as an IO-Link Master, adjustable voltage and current sources, line simulations and so forth.

These snapshots are visualized in an oscilloscope-like view by the PC application. They must be analyzed in a semi-automatic way where measurements are taken by moving graphical cursors that are linked with voltage current and time values. The measured data are entered/copied into predefined fields and used for an automatically generated test report.

### Physical Layer Tester Features

- Compliant to IO-Link Test Specification V1.1.4
- User calibration support
- IODD support
- Integrated IO-Link Master
- Integrated Line Simulation
- Semi-automatic measurement procedure based on recorded waveforms
- SIO – Mode tests
- BIT – and UART Eye-Diagrams
- Test Report Generation (PDF)
- All test results are stored in a reloadable test data file

### Advantages

- All components to run Physical Layer Tests are included
- Substantial reduction of test effort and test duration
- Automatic test report generation

### Deliverables

- IO-Link Physical Layer Tester
- 48V power supply, USB cable
- Connector cables
- Windows-based graphical user interface

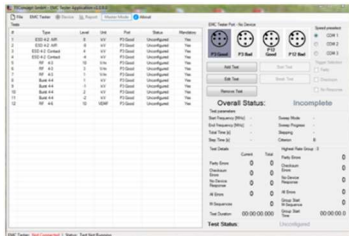

### Overview

The IO-Link specification includes well-defined procedures for testing the EMC robustness of IO-Link devices.

Some tests check the sensitivity of the IO-Link communication of IO-Link devices under EMC conditions.

This requires a robust master that is much less sensitive to EMC noise than the device under test.

This is achieved by separating the IO-Link master into two parts: part 1 contains the sensitive digital logic ( $\mu$ C-box), part 2 contains the IO-Link transceiver (PHY-box).

Both parts are separated by an optical connection with a length of up to 10m.

### Deliverables

- 2 EMC test boxes (Controller-box and PHY-box)
- 6 Optical cables (10m)
- 2 connectors for 24V supply
- EMC Test Graphical User Interface
- PC based IO-Link control tool

### EMC Test Master Features

- Complies to IO-Link interface specification V1.1.2, V1.1.3 and V1.1.4 and the current IO-Link test specification V1.1.4.
- Error and Signal output
- 4 electrical IO-Link port configurations
  - COM1/2 speed port (good signal)
  - COM1/2 speed port (bad signal)
  - COM3 speed port (good signal)
  - COM3 speed port (bad signal)

- RS232 and USB interfaces
- Terminal based control command set
- Additional EMC test and control software with graphical user interface
- Test report generation in PDF Format
- Can be configured to operate as standard "USB IO-Link Master"
- Firmware update supported

### Advantages

- Sensitive Parts are located outside EMC chamber
- EMC robustness



Idea: Standardize Fieldbus mapping for each Fieldbus

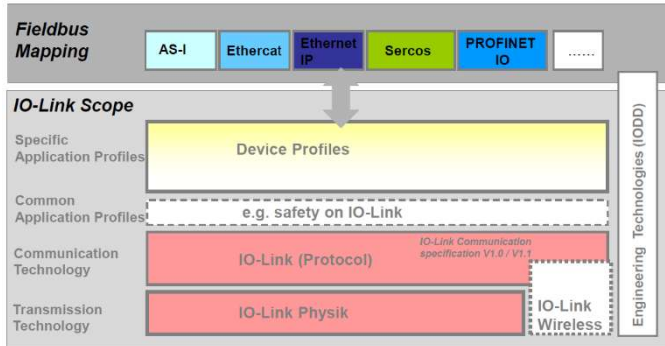

### What is an IO-Link Master?

An IO-Link master is a gateway to the upper level system, which typically is a fieldbus. Other upper level systems can also be SPI, USB, UART, Ethernet or Can. This Gateway application maps between IO-Link data received from IO-Link sensors and IO-Link actuators to the upper level system. The mapping is part of the work of the master manufacturer and is not part of the IO-Link specifications. Therefore, the mapping specification has to be handled by the corresponding fieldbus organization. Publicly available fieldbus mappings are available for Profibus/Profinet, EtherCat, Sercos, ASI and Ethernet IP, for example.

Each master port can be used for an IO-Link device. These device parameter settings could easily be changed with minimal effort. Besides also sensors with switching output work on IO-Link ports.

### SMI

What is SMI?

- SMI is an abstract interface that specifies concrete data structures to control IO-Link Masters
- SMI is located on top of the IO-Link Master Stack
- SMI supports master access from multiple clients
- SMI supports multiple services linked basic master control features in a standardized way

What services does SMI offer?

- Master Identification (VID, serial number, features)
- Port Configuration (Write/Read)
- Port Status information (Read)
- Datastore <-> Parameterserver exchange
- Device Parameter (batch) Write/Read
- Device PowerOff/On (Write/Read)
- PDIn, PDOut (IQ, CQ) (Write/Read PD)
- PDInOut (IQ / CQ) (Sniff PDIn/Out)
- PDRedbackOutIQ (Get IQ values)

### Overview

Current sensors and actuators are equipped with small but powerful microprocessors that introduce advanced features such as parameterization and diagnostics to these devices. However, those features are currently not visible to standardized project planning tools.

IO-Link, the new bi-directional, digital, point-to-point communication standard (IEC 61131-9) now offers standardized mapping of advanced sensor and actuator features into the automation tool environment.

Our IO-Link master software stack allows automation system and machine tool providers an easy way to integrate state-of-the-art IO-Link technology into their products.

### Features

- Complies to latest IO-Link communication specification
- Multi-port support. The number of ports only limited by hardware resources.
- Cycle times: 0,4ms @ 230,4 kBAud
- 2,3ms @ 38,4 kBAud
- 18ms @ 4,8 kBAud
- Footprint: RAM: ~30kB + 5kB/Port
- Flash: ~50kB
- System load max. 20MHz/Port (COM3-speed)
- Standardized Master Interface (SMI) API
- TEConcept SMI Transport Layer (TSTL) support
- Drivers currently available:

Microcontroller	PHY
STM32	CCE4510
RA4M2	CCE4511
RL78G23	L6360
RX72M	LTC2874
RX231	MAX14819
IMX 8M Plus	TIOL112
IMX RT1180	ZIOL2401
and more...	and more...

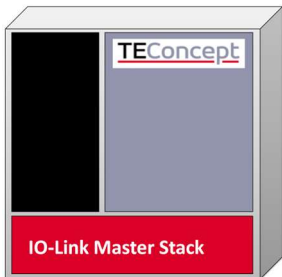

### Description

The IO-Link master firmware library provides full access to all features and services defined in the IO-Link Communication Specification V1.1.4. The stack supports all the important features such as ISDU, Interleaved Mode and diagnostics handling with event details. The new Standard Master Interface "SMI" is fully supported.

### Deliverables

- Development license including IO-Link Master stack source code
- Manufacturing license
- Documentation with installation manual and hardware adaptation description
- API user guide
- Demo application
- Compiler & linker example setups
- IO-Link configuration tool with IODD interpreter

### Additional Services

- Evaluation boards
- Software/Hardware design support
- Conformance tests (Master Tester)



## Master Stack Extension SMI-based Master Bootloader

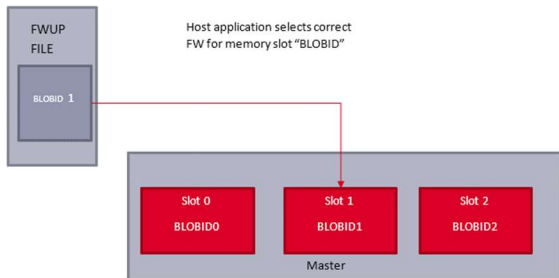

### Overview

The TEConcept firmware update services are executed in a specific mode called "Bootmode" that is distinguished from the Standard Master operational mode that is referred to as "Technology Application mode".

The TEConcept bootloader is based on customer-specific SMI services. During the firmware update process, a binary data sequence is transferred by the bootloader to the Master. This binary sequence is processed by a custom bootloader application (not included), on the Master which is responsible for the interpretation of the binary file.

### Features

- IO-Link V1.1.4 compliant
- Bootloader uses extended SMI services
- Handles power failures during update
- Update process is based on handshake protocols
- Data scrambling / encryption supported
- CRC protection
- Support of multiple FW variants
- Activation of previous variants supported
- Binary and meta data merged into on file
- Packager for file included

### Advantages

- Bootloader transfers firmware binary safely independent from Bootloader-application
- Bootloader application interprets received binary and is responsible for storing the new image and to handle activation of different firmware version identified by BLOBIDs
- Only SMI needed to support firmware update, no special update interface

### Deliverables

- Bootloader Manual
- Description of extended SMI service
- Simple example application
- Packager for metadata and binary image

## Master Stack Extension Serial Transport Layer (TSTL)

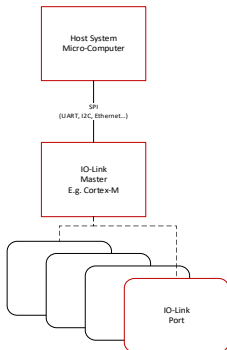
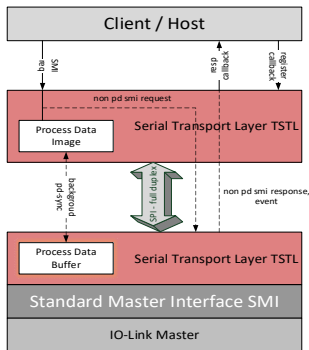

### Overview

The TEConcept Serial Transport Layer "TSTL" connects a separated IO-Link Stack controller to a Host system running on an application microprocessor.

### Description

We have designed a software module for low latency transfer of IO-Link Standard Master Interface Services (SMI) of multiple IO-Link Ports over one serial communication line in an error-robust manner.

### Features

- IO-Link V1.1.4 compatible
- Standard Master Interface "SMI" support
- Sample & Hold synchronization with Ports
- Non-blocking client-side process data access
- CRC based retransmission scheme
- Both full-duplex and half-duplex data transfer
- Configurable, fixed telegram length
- Independent channel for on-request-data
- API needs only 3 interface functions
- Mostly symmetric design
- Currently support for SPI, UART and Ethernet
- C-99 compatible source code

### Advantages

- Extendible to other serial interfaces
- Simultaneous support of multiple IOL-ports with different cycle times
- Deterministic, fast process data exchange
- Independent Parameter/Event processing
- Data access with DMA supported
- Communication seamlessly resumed, if one side temporarily halts operation.
- Immune to transmission errors
- Multiple instances on client-side

### Deliverables

- API Guide
- IO-Link TSTL source files Client side
- IO-Link TSTL source files Master side
- Client Demo Application



## Master Stack Extension SMIT Serial Transport Layer Library

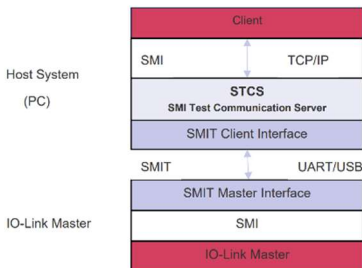

### Overview

The SMI Transfer "SMIT" is a simple communication protocol to exchange SMI messages in an asynchronous request-response manner.

SMIT is integrated into the TEConcept STCS and can be implemented on any IO-Link Master.

SMIT is a simple communication protocol to transfer SMI services over a serial interface e.g. UART or USB with Virtual COM port functionality. It is typically used together with an SMI Test Communication Server, but its library functions can also be used directly by a PC application that is written in C-language.

### Description

The SMIT can transmit SMI requests, responses, and events. It can also catch events and message timeouts. The client-side handles message retransmission on error or timeout.

Message integrity is ensured via CRC.

Offers a lightweight alternative to the TEConcept Serial Transport Layer (TSTL).

### Features

- Transmission of SMI requests
- Reception of SMI responses and events
- Integrity check with CRC
- Message response timeout check
- Request retransmission on error
- Supports UART and USB
- ANSI compatible source code and template

### Advantages

- Simplicity
- Small code footprint on master
- Portable

### Deliverables

- STCS Executable with SMIT
- SMIT C library in source code
- Template for Master integration
- Documentation

## Master Stack Extension SMI Test Communication Server

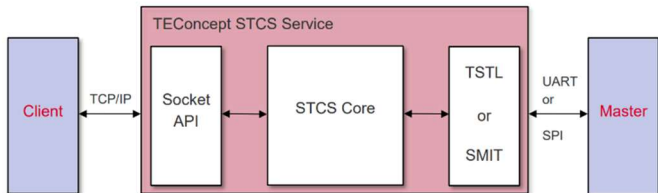

### Overview

The TEConcept SMI Test Communication Server "STCS" connects multiple TCP clients and an IO-Link Master according to the IO-Link V1.1.4 test specification with TSTL or SMIT interfaces.

The TEConcept STCS is available as an executable program that runs on desktop Windows and Linux systems.

Alternatively, the TEConcept STCS is available as a software development kit with the basic library in source code for special client systems such as embedded controllers.

### Description

The SMI Test Communication Server uses TEConcept's TSTL or SMIT protocol to communicate with an appropriate IO-Link Master. The STCS provides simple connection setup and different logging levels for message monitoring.

A free version of the STCS is shipped together with USB Masters from TEConcept as an executable program.

An expert version for professional use in embedded systems with low latency process data handling and additional SPI support is offered as Software Development Kit including source code.

### Features

- IO-Link V1.1.4 compatible
- Executables for Linux and Windows
- Configurable via Command Line Parameters
- Support for UART and USB in public version
- Expert Version with low latency Process data exchange and SPI support
- Expert version with ANSI compatible source code

### Advantages

- Integrated TSTL and SMIT as communication protocol for the master

### Deliverables

- STCS executable (Windows or Linux)
- Manual
- Expert Version with source code and example projects



## JSON Integration for IO-Link

### Overview

One of the significant challenges of IoT- and cloud-based systems is the specification of a secure and straightforward communication interface with industrial field devices.

The fact that most modern automation systems can communicate via TCP/IP and HTTP provided the motivation for the IO-Link Consortium to create a standardized JSON-based communication specification for IO-Link.

The integration provides a device data model, objects, and semantics for mapping the IO-Link system into IT relevant connections and services. This includes a standard REST API based for:

- Data access for IO-Link Master/Ports/Devices
- IODD management
- MQTT client configuration

### Advantages

- Easy integration to any JSON based client such as PDCTs, HMI, etc.
- Easy integration to Node-RED and Cloud systems
- Convenient means for diagnostics and parameterization
- Possibility for web-based supervision of the IO-Link system

### License Model

- NRE based, royalty-free license
- One-year maintenance included
- Full source code transfer

### Requirements

- V1.1.3 or later IO-Link Master stack (with SMI interface)
- RTOS or Linux/Windows operating system
- Ethernet connection using a TCP/IP stack
- ARM Cortex M4, M7 controller, or any system which can run Linux or Windows.
- Moderate memory requirements suitable for Cortex-M-based processor platforms

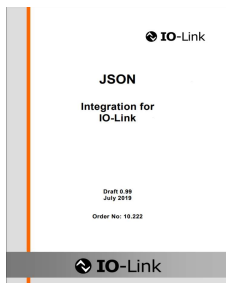

### Deliverables

- JSON Integration for IO-Link module source code, written in ANSI C (can be compiled on embedded platforms and also on Linux/Windows-based systems)
- Web server using sockets (if supported)
- Integrated IODD parser
- Demo application
- JSON API documentation



## IODD Parser in C

```
<?xml version="1.0" encoding="UTF-8"?>
<xsd:schema xmlns="http://www.io-link.com/IODD/2010/10" xmlns:xs="http://www.w3.org/2001/XMLSchema-1" >
  <xsd:include schemaLocation="IODD-Primitives1.xsd"/>
  <xsd:include schemaLocation="IODD-DataType1.xsd"/>
  <xsd:include schemaLocation="IODD-Event1.xsd"/>
  <xsd:include schemaLocation="IODD-StandardDefinitions1.xsd"/>
  <xsd:element name="IODDStandardDefinitions" type="IODDStandardDefinitions" >
    <!-- unique, key -->
    <xsd:unique base="Variable_Index" >
      <xsd:selector xpath="//IODD:Variable" >
        <xsd:field xpath="@index" >
        </xsd:field >
      </xsd:selector >
    </xsd:unique >
    <xsd:key name="Variable_Id" >
      <xsd:selector xpath="//IODD:Variable" >
        <xsd:field xpath="@id" >
        </xsd:field >
      </xsd:selector >
    </xsd:key >
  </xsd:element >
</xsd:schema >
```

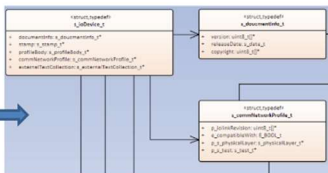

### Overview

In order to use the information given in an IODD, it is necessary to parse the IODD text file and to convert it into a hierarchical memory model layout. These IODD parsers are typically included within engineering tools running on a PC that allow parameterization and configuration of IO-Link Devices.

However, there are use cases where it is beneficial to have the respective memory layout available in an embedded system that is directly linked to an IO-Link Master.

One use case is a web server that is implemented in an IO-Link Master hardware. An IODD parser allows integration of an embedded web server that provides access to parameters, events, system commands etc. of any Device that is connected to the IO-Link master after having parsed the corresponding IODD.

TEConcept has developed an IODD Parser that is suitable for integration in embedded systems. It is designed to make very efficient use of embedded memory and it has been tested with a large number of IODDs of different Devices.

### Deliverables

- C-source code
- API description
- Test report

### IODD Parser Features

- Complies to IO-Link Interface Specification V1.1.2 / V1.1.3
- Complies to current IODD-specification (V1.1) and V1.0 (August 2011)
- IODD import as text-file (string, stream)
- Average parsed IODD size = 20kByte
- Max parsed IODD size (CLUETEC Server, April 2018) 100 kByte
- Simple user API
- Memory model organized as linked tree structure
- Programming language "C"
- Suitable for embedded Systems

### Advantages

- Support Design of "intelligent" IO-Link Masters
- Efficient memory usage
- Error checking included
- Simple to use API

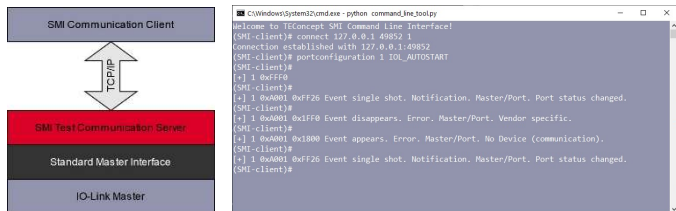

### Overview

The TEConcept SMI Communication Client “SCC” provides access and control to any V1.1.4 compatible IO-Link Master via the SMI Test Communication Server (STCS) as specified in the IO-Link V1.1.4 test specification. Runs on any system which supports Python 3 (Windows, Linux, etc.).

### Description

SCC can be used for easy interaction with IO-Link Masters via SMI and is useful for debugging and test automation. It provides a Command Line Interface for interactive operation. Commands are executed serially in request – response style. SMI libraries are also available for scripted operations, thus custom control logic can be easily implemented.

### Features

- Interactive Command Line Interface
- Simple, text-based commands
- Command history
- Automatic reconnection
- Detailed SMI Service Arguments interpretation
- Octet string based custom SMI Service execution
- Plug-in system for vendor specific SMI Services
- Connection manager which handles the asynchronicity of the communication with the IO-Link

### Advantages

- Useable from remote location (over TCP/IP socket)
- Hides communication complexities
- Suitable for analysing the SMI Service Arguments and ArgBlocks
- Simultaneous interaction with multiple Masters from script
- Support for out of specification values for testing purposes
- An STCS server that connects to TEConcept IO-Link Masters via USB, SPI, UART etc. is provided together with the SCC

### Additional Services

- Safety extension
- Wireless extension
- BLOB transfer & Device FW update extension

### Deliverables

- Manual with detailed examples
- STCS binary (Windows or Linux)
- Python SCC package

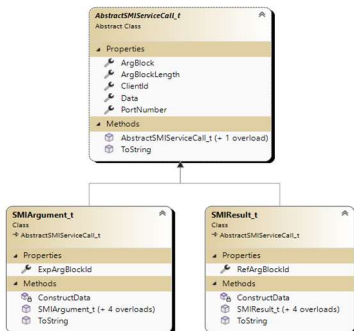

## Overview

The structure of an SMI service argument is described in the IO-Link Interface and System Specification V1.1.4. This library implements intuitive and easy to use class definitions for creating and parsing standardized and vendor specific ArgBlocks.

Each class has Constructors for serializing and deserializing ArgBlock Payload and Header data, providing a human readable form of ArgBlock Payload data.

The library contains generic classes for:

- Arg Block Parsing – The interpreter constructor helps to decode (parse) the raw SMI Response ArgBlock data.
- ArgBlock Composing – The composer constructor helps to construct a new SMI Request ArgBlock data.

The serialized data can be easily used to send out SMI requests over any vendor specific interface. Deserialized responses can be used as human readable data for visualization and GUI application such as:

- console-based loggers
- simple data acquisition applications
- plotting
- etc.

## SMI Composer-Parser in C# Features

- Easy integration as NuGet package
- Available for all new .NET framework versions
- Implementation of Vendor Specific ArgBlock Extensions is possible

## Advantages

- Easy integration
- Simple binary format

## Deliverables

- User Guide
- NuGet package version
- Source code version
- DLL version
- Simple demo application to showcase usage



### Overview

Current sensors and actuators are equipped with small but powerful microprocessors that introduce advanced features such as parameterization and diagnostics to these devices. However, those features are currently not visible to standardized project planning tools.

IO-Link™, the bidirectional, digital, point-to-point communication standard (IEC 61131-9) now offers standardized mapping of advanced sensor and actuator features into the automation tool environment.

The 1-Port USB-C Master is ideally suited for engineering purposes and small PC-based applications. It is now powered by the USB-C port. Devices with a current consumption of up to 500mA are supported. It supports the new SMI interface. The SMI-services are ex-changed by the TEConcept serial transport layer protocol between PC and Master.

A Windows based graphical user interface is included that reads IO-Link device descriptor "IODD" files and offers an easy way to connect to all kinds of IO-Link devices. The GUI communicates with the Master via a TCP/IP that connects to an STCS server (see IO-Link Test Specification A3.3) that map SMI services in USB-telegrams.

### Usage

- Engineering purposes and small PC-based applications
- Test Systems
- Simple evaluation of devices
- Engineering support
- Device Development

### Features

- Fully IO-Link V1.1.4 compliant
- All COM-speeds supported
- Data storage supported
- M12 IO-Link connector
- DIN rail mount
- USB-C powered (5V 3A)
- PC Tool included with
  - IODD interpreter
  - Process data visualization
  - Event visualization
  - Parameter R/W access
  - IODD menu structure support
  - IODD user role support
  - Socket interface for process data



### Deliverables

- 1-Port IO-Link V1.1.4 master
- IO-Link control tool V4.0
- USB-C cable
- STCS-Server

## 4-Port USB Master

### Overview

Current sensors and actuators are equipped with small but powerful microprocessors that introduce advanced features such as parameterization and diagnostics to these devices. However, those features are currently not visible to standardized project planning tools.

IO-Link™, the new bi-directional, digital, point-to-point communication standard (IEC 61131-9) now offers standardized mapping of advanced sensor and actuator features into the automation tool environment.

The 4-Port USB Master is ideally suited for engineering purposes and small PC-based applications.

A Windows-based graphical user interface "Control Tool" is included that reads IO-Link device descriptor files (IODDs) and offers an easy way to connect to all kinds of IO-Link devices.

### Deliverables

- 4-Port IO-Link master
- 24V power supply
- IO-Link Control Tool
- USB cable (Type B)

### Features

- Fully compliant to IO-Link V1.1.4
- Master Firmware update
- All COM speeds supported
- Data storage supported
- Class A M12 IO-Link connector
- DIN Rail Mount
- PC Tool included with
  - IODD Interpreter
  - Process data visualization
  - Event visualization
  - Parameter R/W access
  - IODD menu structure support
  - IODD user role support
  - Socket interface for process data
- Option: Windows DLL for customized and software-based access to the Master

### Usage

- Test Systems
- Simple evaluation of devices
- Engineering support
- Device Development





Use  **IO-Link**  
Universal · Smart · Easy

## 1-Port Master Module

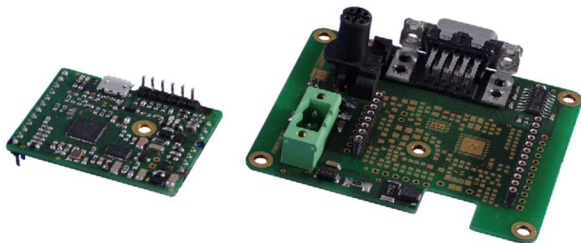

### Overview

The IO-Link 1-Port Master Module provides easy access to IO-Link devices without PLC.

The IO-Link master module contains an IO-Link compliant transceiver PHY together with a controller running a fully compliant IO-Link master stack.

The IO-Link master module can communicate with external hardware via SPI and/or UART interfaces.

Simple telegrams sent over these interfaces allow control of the master and provide easy access to process data and IO-Link configuration and diagnostic features.

Device configuration can be done offline via an integrated USB connector by a PC running a comfortable and self-explaining IO-Link control tool.

The module can be plugged onto an existing board. For development purposes a reference motherboard is available.

### Features

- Fully compliant with V1.1.4 IO-Link interface specification
- IO-Link V1.1.4 compatible stack
- Integrated IO-Link transceiver with protection
- L+ device power switchable
- SPI interface for control and process data
- UART interface for control and process data
- USB interface for PC control
- Dimensions: 43 mm x 33 mm

### Motherboard Features

- 24 V power supply connector
- DB-9 serial connector
- Power supply for IO-Link master module
- M12 IO-Link Master connector

### Typical Applications

- Seamless integration of IO-Link devices into machine control or similar systems that work without classic PLCs.

### Deliverables

- 1-port IO-Link master module
- Motherboard with IO-Link master module plug with SPI and UART interface
- IO-Link control tool for easy configuration of arbitrary IO-Link devices with integrated IODD parser
- Manual

### Advantages

- Development effort and cost reduced
- Time to market shortened

## 4-Port Master Module

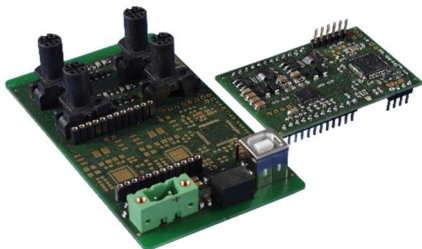

### Overview

The IO-Link 4-Port Master Module provides easy access to IO-Link devices without PLC.

The master module contains 4 fully tested IO-Link compliant transceiver PHYs together with a controller running a fully compliant IO-Link master stack.

The IO-Link master module can communicate with external hardware via SPI and/or UART interfaces.

Simple telegrams sent over these serial interfaces allow communication with the master and provide easy access to process data and IO-Link diagnostic information of up to 4 connected devices.

Device configuration can be done offline via an integrated USB connector by a PC running a comfortable and self-explaining IO-Link control tool.

The module can be plugged onto an existing board. For development purposes a reference motherboard is available.

Optionally, for low cost stand-alone mini PLC systems, customization of the 4-port master application software can be offered.

### Deliverables

- 4-Port IO-Link master module
- Motherboard with IO-Link master module plug and SPI and UART interface (optional)
- IO-Link control tool with integrated IODD parser for easy configuration of IO-Link devices of choice
- Manual

### Features

- Fully compliant with V1.1.4 IO-Link interface specification
- IO-Link transceiver and protection integrated
- L+ device power switchable
- SPI interface for control and process data
- UART interface for control and process data
- USB interface for PC control
- Dimensions: 59 mm x 39 mm

### Motherboard Features

- 24V power supply connector
- DB-9 serial connector
- Power supply for IO-Link master module
- M12 IO-Link master connector

### Typical Applications

- Seamless integration of IO-Link devices into machine control or similar systems that work without classic PLCs.
- Stand-alone systems which integrate IO-Link devices and actors (e.g. level sensor with signal tower)

### Advantages

- Development effort and cost reduced
- Time to market shortened
- Cost advantages as no IO-Link master stack is required

### Additional Services

- Optionally, for low cost stand-alone mini PLC systems, customization of the 4-port master application software can be offered.



## 4-Port Ethernet IO-Link Master

### Overview

Discover the power of our 4-Port **Ethernet** IO-Link Master, focusing on Industry 4.0 IIoT (Industrial IoT) integration of IO-Link Devices. The Ethernet-based communication interface makes it easy to talk to IO-Link Devices via the Master unit without any field bus.

An integrated JSON interface which follows the "JSON Integration for IO-Link" specification makes it possible to connect to IO-Link Devices from any software application that supports the JSON data format. The Device **parameters** and **process data** are accessible via JSON data units which considerably simplifies configuration, data acquisition and even diagnostic tasks.

All third-party parameterization and configuration tools which implement the JSON Integration are supported. However, TEConcept's well established IO-Link Control Tool can still be used to access the 4-Port Ethernet IO-Link Master.

An integrated web GUI offers a convenient interface for:

- IO-Link gateway / Network configuration
- IO-Link Port configuration
- IO-Link Device configuration
- IODD-less ISDU parameterization
- Basic security settings
- SNTP time synchronization

### Deliverables

- 4-Port Ethernet master
- IO-Link Control Tool

### Features

- IO-Link V1.1.3 compatible Master
- Ethernet/TCP-IP interface
- DHCP or static IP address configuration
- Standardized JSON mapping
- Node-RED integration supported
- 4 independently powered IO-Link Class A ports

### Advantages

- Direct IO-Link Device access over Ethernet without Fieldbus and PLC
- Easy Node-RED integration for IIoT and industry 4.0 setups
- Extendible by freely programmable MCU
- Customized OEM enclosure possible



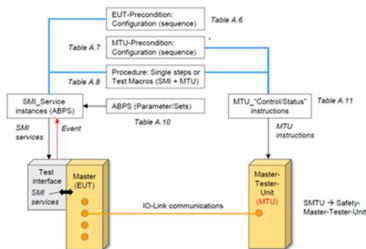

### Overview

Every manufacturer of IO-Link Masters needs to run the tests specified in the current IO-Link Test specification V1.1.4 (September 2024) successfully as precondition for the manufacturer's declaration of conformance.

In IO-Link V1.1.3, a standard master interface "SMI" was introduced, which specifies methods to communicate with an IO-Link Master in an abstract way.

IO-Link Test Specification for the Master Test was substantially updated.

The Master Tester communicates via SMI Services with SMI Test Communication Server "STCS" to be provided by the Master manufacturer, which maps SMI services to a concrete Master.

The Master Tester V1.1.4 is completely redesigned. It is based on a Master Tester Application "MTA" that runs on Windows 7 and newer and a Master Tester Unit "MTU" as specified in the IO-Link Test specification.

### Advantages

- Highly automated test of IO-Link Masters
- Allows testing of IO-Link masters without fieldbus or backplane gateway
- Test report suitable for Manufacturer's Declaration
- One year maintenance included

### Master Tester Features

- Test system for automated, reproducible IO-Link Master tests according to the IO-Link test specifications Rev 1.1.4 / Sept. 2024
- PDF Report Generation
- Simultaneous testing of multiple ports supported (requires additional MTUs)
- SDK for SMI Test Communication Server
- Maintenance extension provided
- Option for additional MTUs

- Approved by IO-Link community
- Upgrade from MT V1.1.2 possible ("Golden-Device" from MT V1.1.2 needs to be replaced).

### Deliverables

- Master Tester Application "MTA" installer
- VID locked license key (for Master manufacturers)
- Optional unlocked license key for Test labs
- One Master Tester Unit
- USB-Cable
- SDK for SMI Test Communication Server
- Python based SMI control application
- Copy of approval document



Use  **IO-Link**  
Universal · Smart · Easy

## EMC Test Device



### Overview

The IO-Link Interface Specification V1.1.5 defines a specific Test Device (see Appendix H.2.2 Test of a Master) that shall be connected to an IO-Link Master during the execution of EMC tests.

### Functional Description

The Device generates an 8-bit random number which is read out by the Master. During the test the Master shall return this random number to the Device in the next IO-Link cycle.

The Device checks whether it receives the correct random number and increments an internal error counter if not. The error counter is also incremented if a checksum error or a parity error is detected on the Device side.

The error count can be read out by the Master via an IO-Link parameter after the test. In addition, the error counter value is also displayed by a 7-segment indicator.

When an error is detected, the Device generates a trigger signal at an optical output. A trigger box that converts the optical signal into a trigger pulse can be connected to the Device. The trigger pulse supports developers in identifying possible issues on the Master side.

The Device can be configured to operate in one of three COM-speeds by DIP-Switches or by IO-Link Parameters.

### EMC-Test-Device Features

- Device fully compliant to V1.1.5 IO-Link Interface Specification
- All three COM-Speeds supported (via Switch Selector and IO-Link Parameter)
- Internal Pseudo-Random-Number Generators
- Error counter for Parity, Checksum, Data and Time-out Errors
- 7-Segment Error Counter Display
- 7-Segment Device Status Display
- Error Counter accessible via IO-Link
- Optical Error Trigger Output
- Optional Ready-Pulse at Device start-up
- Additional support of round-trip delay measurements
- Total error counts and maximum error counts within standardized group of M-Sequences separately available via IO-Link. Two group sizes selectable per COM-Speed.

### Advantages

- Better time-to-market
- Identification of EMC issues

### Deliverables

- IO-Link EMC Test device (with IODD)
- IO-Link Trigger box
- Optical link



## Distributors

### USA



**Grid Connect Inc.**  
1630 W Diehl Rd  
NAPERVILLE, IL 60563  
USA  
Tel.: +1 (630) 245-1445  
E-mail: [store@gridconnect.com](mailto:store@gridconnect.com)  
Web: [www.gridconnect.com](http://www.gridconnect.com)

### Asia



**Arrow Asia Pac Ltd. ("Arrow Asia")**  
2/F, Green 18, Phase 2,  
Hong Kong Science Park,  
Pak Shek Kok,  
N.T., Hong Kong  
Tel.: +852-2484 2484  
E-mail: [sales.hongkong@arrowasia.com](mailto:sales.hongkong@arrowasia.com)  
Web: [www.arrow.com](http://www.arrow.com)

### Japan



**M2M craft Co., Ltd.**  
Mr. Yuto Mochizuki  
N23 bldg. 5-2-39,  
Kita 23-jo Nishi, Kita-ku  
001-0023 Sapporo  
JAPAN  
Tel.: +81 11 788 9422  
E-mail: [mochizuki@m2mcraft.co.jp](mailto:mochizuki@m2mcraft.co.jp)  
Web: [www.m2mcraft.co.jp/en](http://www.m2mcraft.co.jp/en)

### China



**Nanjing Loyst Industrial Networks Co., Ltd.**  
Mr. Zhaoji "George" Duan  
Room 1701, No 33 Building,  
Office Park, No. 70 Feinikesi Road  
211100 Nanjing  
P.R. CHINA  
Tel.: +86-25-84 91 67 68  
E-mail: [zhaoji.duan@hostamc.cn](mailto:zhaoji.duan@hostamc.cn)  
Web: [www.loystnetwork.com](http://www.loystnetwork.com)

### Korea



**EmbedCoreTech**  
Mr. JunBeom Kim  
B-723, 282 HAKEUI-RO, DONGAN-GU  
14056 ANYANG-SI  
KOREA  
Tel.: +82-31-396-5584  
E-mail: [jbkim@e-coretech.kr](mailto:jbkim@e-coretech.kr)  
Web: [www.e-coretech.kr](http://www.e-coretech.kr)



## Partnerships

### IO-Link Community



#### IO-Link Community

Ohiostraße 8  
76149 Karlsruhe  
Germany  
Tel.: +49 721 96 58 590  
E-mail: [info@io-link.de](mailto:info@io-link.de)  
Web: [www.io-link.com](http://www.io-link.com)

#### TEConcept's contribution:

- Steering Committee Member
- Working Groups
- IO-Link-Competence Center
- IO-Link-Test Center

### IO-Link Wireless



#### CoreTigo Ltd.

Israel – Headquarters  
Giborei Israel 5  
Netanya, 4250405  
Israel  
E-mail: [info@coretigo.com](mailto:info@coretigo.com)  
Tel.: +972-747-69-10-20  
Web: [www.coretigo.com](http://www.coretigo.com)

### Manufacturer of Microcontrollers



#### Analog Devices

Web: [www.analog.com](http://www.analog.com)

AHEAD OF WHAT'S POSSIBLE™



#### STMicroelectronics N.V.

Web: [www.st.com](http://www.st.com)

life.augmented



#### Renesas Electronics Corporation

Web: [www.renesas.com](http://www.renesas.com)



## Zertifikat

# IO-Link-Competence Center

Hiermit wird der

**TEConcept GmbH**

Wentzingerstr.21, 79106 Freiburg

Germany

die erfolgreiche Zertifizierung für IO-Link Competence Center gemäss dem  
"Quality of services agreement" bescheinigt

Dieses Zertifikat wurde ausgestellt am

**1. July 2025**

Zertifikat Nr: C25-004

Diese Zertifikat endet 2027-06-30

IO-Link community • Ohiostr. 8 • 76149 Karlsruhe • Germany • [www.io-link.com](http://www.io-link.com)





# Zertifikat

## IO-Link-Test Center

Hiermit wird der

**TEConcept GmbH**

Wentzingerstr. 21, 79106 Freiburg

Germany

die erfolgreiche Zertifizierung für IO-Link Test Center gemäss den Regeln "How to Become and to Run an Accredited IO-Link Test Center" bescheinigt

Diese Zertifikat wurde ausgestellt am

**1. June 2023**

Zertifikat Nr: C23-102



Diese Zertifikat endet 2026-06-01

IO-Link community • Haid-und-Neu-Str. 7 • 76131 Karlsruhe • Germany • [www.io-link.com](http://www.io-link.com)





## DECLARATION OF TEST TOOL ACCEPTANCE

### The IO-Link Test Tools of

TEConcept ([www.teconcept.de](http://www.teconcept.de))

1. IO-Link Device Tester V1.1.3
2. IO-Link Master Tester V1.1.3
3. IO-Link Physical Layer Tester V1.1.3
4. TEConcept Diag. Tool V1.5
5. Test Device for Firmware Update and BLOB (FWBD) V1.1
6. IO-Link Safety Master Tester V1.1.3
7. Configurable Observable Device V1.01

*where tested on Interoperability workshop on  
october 1<sup>st</sup> / 2<sup>nd</sup> 2024 in Bad Soden  
(Germany)*

The tools are approved for compliance tests  
of IO-Link products related to package 2024

Issued at Bad Soden (Germany), 2024-10-02

### Authorized signatory

**Name:** Frank Moritz  
**Title:** Head of IO-Link Quality

**Signature:**

2024

Published 19.12.2024



## References



## Scan and Browse!



[www.teconcept.de](http://www.teconcept.de)



## **Interested? Feel free to Contact us!**

### **TEConcept GmbH**

Wentzingerstr. 23

79106 Freiburg

Germany

E-mail: [info@teconcept.de](mailto:info@teconcept.de)

Phone: +49 761 21443640

Fax: +49 761 21443631

Web: [www.teconcept.de](http://www.teconcept.de)

### **TEConcept Hungary Kft**

Csongrádi sgt.11/A

6721 Szeged

Hungary

E-mail: [info@teconcept.de](mailto:info@teconcept.de)

Phone: +36 62 276 016

Web: [www.teconcept.de](http://www.teconcept.de)